

Application Note

AN-ODP-45

Connecting multiple motors in parallel

Author: Peter Evans, Glyn Jones, Invertek Drives Ltd

Revision: 2.21 6 September 2006

- **General:**

In some fan applications it is possible to operate the Optidrive with multiple motors and long cable lengths. This application note defines guidelines on how to size your drive to match your application demands. These guidelines are designed for use in Fan applications only, for other application please consult Invertek Drives.

Figure 1 illustrates a typical application setup for operating the Optidrive with multiple motors and long cable lengths.

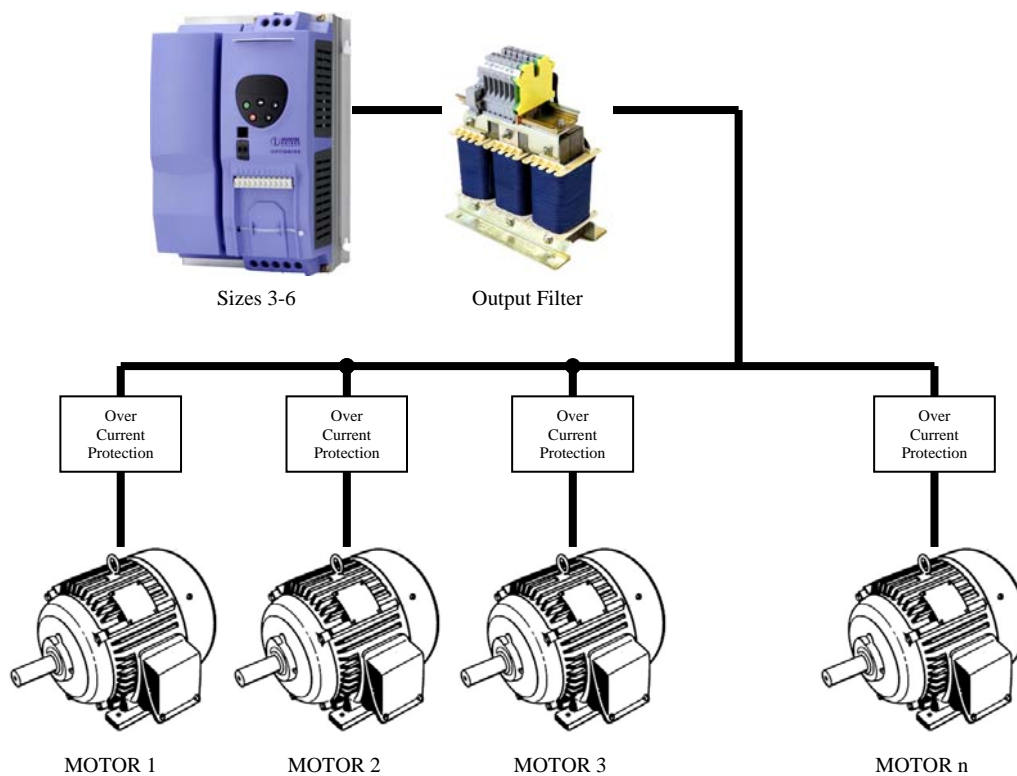

Figure 1 – Parallel motor configuration

- **General Rules For Sizing The Drive:**

1. It is recommended that motors are only connected in parallel on Optidrive Sizes #3 to #6. Sizes #1 and #2 are not suitable for parallel connection or for total cable lengths in excess of 100m.
2. Total cable length of the attached motors is not to exceed 500m. This is appropriate for all cable types e.g. Pyro, armoured, shielded, Non-shielded. For longer cable length requirements please consult Invertek Drives Ltd.
3. An appropriately sized output filter (choke) MUST be fitted.
4. To avoid motor overload/damage, please fit individual motor overload protection. Never connect or disconnect any motors to the system whilst the drive is running e.g. by closing a output contactor. This can cause excessive current peaks and possible drive over-current trips (O-I) and / or possible damage to the drive.
5. The drive current rating should be at least 20% larger than the total load current. This will compensate for the demands on starting the load and the long cable lengths attached.

- **Parameter Settings:**

The drive switching frequency should be set to a minimum (P2-24 = 4kHz). Increasing the switching will increase the losses in the output filter generating more heat.

The output current rating of the drive should be set to match the current rating of the output choke (if less than the drive rating). This will give overload protection for the output choke, but not each individual motor.

The Optidrive Plus should only be used in V/F mode (P4-01=2) when motors are connected in parallel. It is not possible to operate in Vector control with parallel motors.

Using acceleration rates that are too short can result in the motors stalling and failing to start correctly, we therefore recommend extending the ramp times from the default drive setting to avoid this.

- **Example:**

For an application requiring 6 * 2.2 kW, 4.8A, 400V motors in parallel each mounted 75m from the drive, the following would apply:

Total Load Current Required = $6 * 4.8A = 28.8A$

Drive Current Required = Total Current + 20% = 34.6A

Optidrive Model Required = ODP-44185-xx, 380-480V $\pm 10\%$, 18.5kW, 39A

Output Filter = OD-OUTF4-xx = 3 phase, 75A

Total cable length not to exceed 500m, therefore $6 * 75m = 450m$, cable length is within limits.

--- End ---