

Application Note

AN-ODP-25

Configuring the drive for remote push-button speed control

Author: Ning Xu, Invertek Drives Ltd

Revision: 2.21 6 September 2006

• **General**

In some applications, especially those where the drive is build into an enclosure, the speed of the motor is controlled using push-buttons mounted on the front of the enclosure. This application note describes how this can be implemented.

• **Wiring:**

For those applications, where a dedicated start and stop button are required, then the system can be configured as follows:

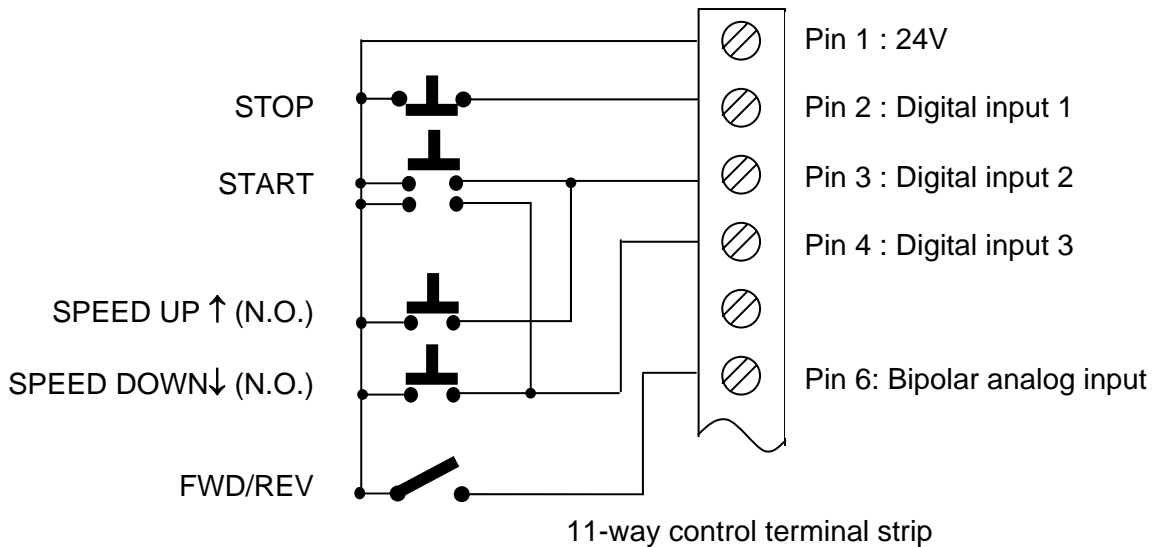

• **Procedure :**

For unidirectional operation:

1. Connect the system as showed above, leaving terminal pin 6 disconnected.
2. Set P1-12=1. Set P2-01 = 0 (see digital input selection options in table 5.6 of the User guide).
3. Set P2-19 = 0 if the drive should always restart form 0Hz (or minimum speed limit if P1-02 > 0). Set P2-19 = 1 if the drive should restart from the speed at which it was last running prior to the last STOP.

4. Press the <START> button to start the drive or press the <STOP> button to stop the drive.
5. Once the drive is running, press the UP button to increase the speed or press the DOWN button to reduce the speed.

For bidirectional operation:

1. Connect the system as showed above.
2. Set P1-12 = 2. Set P2-01 = 3 (see digital input selection options in table 5.6 of the User guide).
3. Set P2-19 = 0 if the drive should always restart form 0Hz (or minimum speed limit if P1-02 > 0). Set P2-19 = 1 if the drive should restart from the speed at which it was last running prior to the last STOP.
4. Press the <START> button to start the drive or press the <STOP> button to stop the drive.
5. Once the drive is started, press the UP button to increase the speed or press the DOWN button to reduce the speed.
6. Using the FWD/REV switch connected to terminal 6 to control the speed direction. Open the switch for forward operation and close switch for reverse operation

For safety-critical applications, place an additional enable switch between pin 1 (0V) of the terminal strip and the push-buttons. When this switch is open, the push-buttons are inoperative and the drive cannot start.

--- End ---